



<b>IMPORTANT FOR FUTURE REFERENCE</b> Please complete this information and retain this manual for the life of the equipment:
Model #: _____
Serial #: _____
Date Purchased: _____

## Installation & Operation Manual

# Electric Counter Pan Steamers EPX-3 & EPX-5



Model EPX-5

### **WARNING**

Improper installation, adjustment, alteration, service or maintenance can cause property damage, injury or death. Read the installation, operating and maintenance instructions thoroughly before installing or servicing this equipment.

### **CROWN FOOD SERVICE EQUIPMENT**

 **MIDDLEBY** A Middleby Company

70 Oakdale Road, Downsview (Toronto) Ontario, Canada, M3N 1V9

Telephone: 919-762-1000

[www.crownsteamgroup.com](http://www.crownsteamgroup.com)



# SAFETY PRECAUTIONS

Before installing and operating this equipment, be sure everyone involved in its operation is fully trained and aware of precautions. Accidents and problems can be caused by failure to follow fundamental rules and precautions.

The following symbols, found throughout this manual, alert you to potentially dangerous conditions to the operator, service personnel, or to the equipment.



This symbol warns of immediate hazards that will result in severe injury or death.



This symbol refers to a potential hazard or unsafe practice that could result in injury or death.



This symbol refers to a potential hazard or unsafe practice that could result in injury, product damage, or property damage.



This symbol refers to information that needs special attention or must be fully understood, even though not dangerous.

## IMPORTANT NOTES FOR INSTALLATION AND OPERATION

### WARNING

This is the safety alert symbol. It is used to alert you to potential personal injury hazards. Obey all safety messages that follow this symbol to avoid possible injury or death.

### WARNING

WARNING: Improper installation, operation, adjustment, alteration, service or maintenance can cause property damage, injury or death. Read the installation, operating and maintenance instructions thoroughly before installing, operating or servicing this equipment.

### WARNING

Never spray water in electrical components.

### NOTICE

Unit must be level to assure proper performance.

### NOTICE

This product is intended for commercial use only. NOT FOR HOUSEHOLD USE.

### NOTICE

This manual should be retained for future reference.

It is recommended that this manual be read thoroughly and that all instructions be followed carefully.

RETAIN THIS MANUAL FOR FUTURE REFERENCE.

## Table of Contents

Important Notes For Installation and Operation .....	2
Service Connections .....	4
Introduction .....	5
Installation Instructions .....	6
Testing Procedures .....	8
Operation .....	9
Cleaning.....	11
Cooking Guidelines.....	12
Preventive Maintenance .....	13
Troubleshooting .....	15

# SERVICE CONNECTIONS

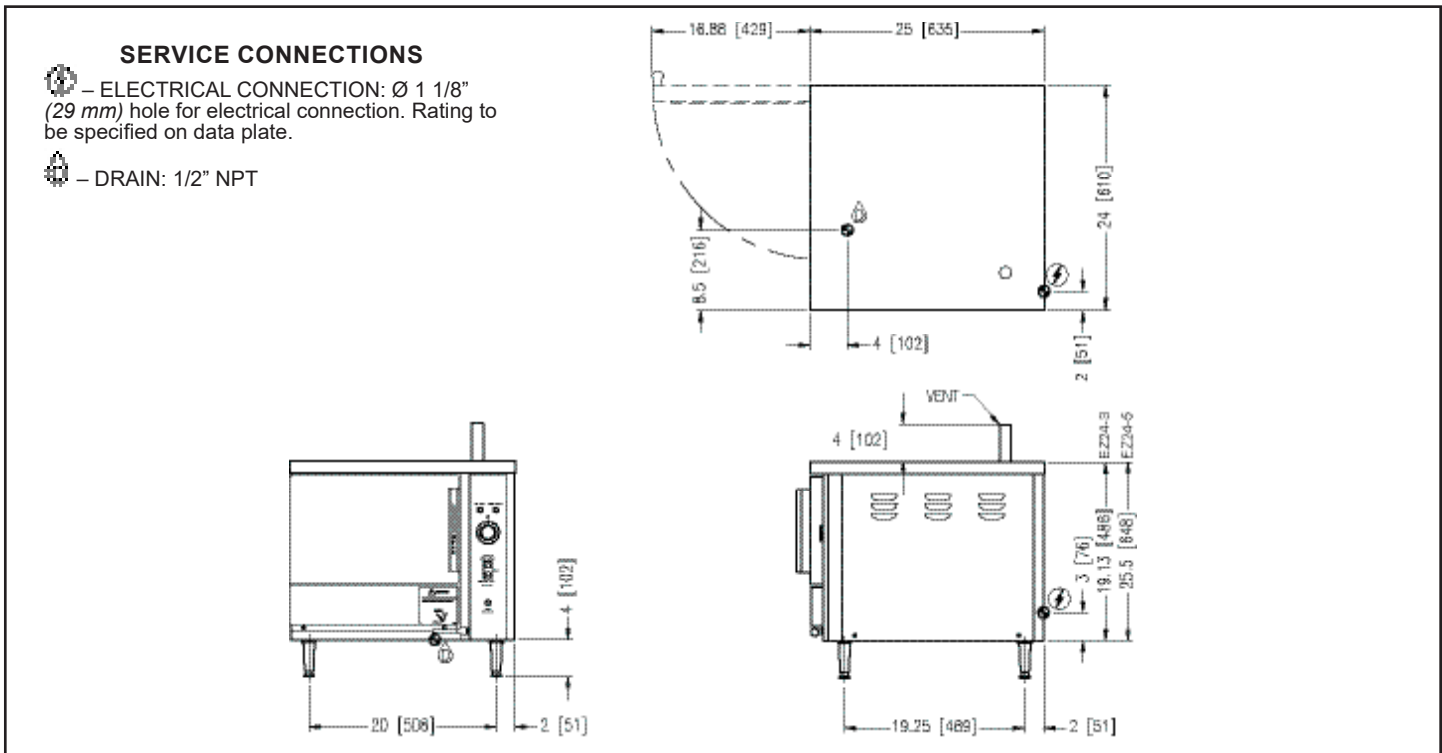

## ELECTRICAL CHARACTERISTICS

MODEL	kW	AMPS/PHASE									
		208V		220V		240V		380V	415V	480 V	600V
		1 PH	3 PH	1 PH	3 PH	1 PH	3 PH	3 PH	3 PH	3 PH	3 PH
EPX-3	9	43.3	25.0	40.9	23.6	37.5	21.7	13.7	12.5	10.8	8.7
	6	28.9	N/A	27.3	N/A	25.0	N/A	N/A	N/A	N/A	N/A
EPX-5	15	72.1	41.6	68.2	39.4	62.5	36.0	22.8	20.9	18.0	14.4
	10	48.1	N/A	45.5	N/A	41.7	N/A	N/A	N/A	N/A	N/A

## COMPARTMENT PAN CAPACITY

MODEL	PAN DEPTH	INCHES MM	1"	2.5"	4"	6"	SHIPPING WEIGHT	MINIMUM CLEARANCE	
			25	64	102	152		SIDES	0
EPX-3	Total Quantity of Pans		6	3	2	1	161 lbs. [73 kg]	SIDES	0
EPX-5			10	5	3	2	183 lbs. [83 kg]	BACK	3

## WATER QUALITY STATEMENT

Water is the essential ingredient in steam equipment, water quality is the major factor affecting the performance of your appliance. Crown Steam Group offers a Comprehensive Water Treatment System as an option (at additional cost) which exceeds our minimum water requirements. Proof of installation and proper cartridges replacement is required for warranty coverage. Water supply to Crown Steam Group steamers must be within these guidelines.

- Total dissolved solids.....Less than 60 PPM
- Total alkalinity .....Less than 20 PPM
- Silica.....Less than 13 PPM
- Chlorine .....Less than 1.5 PPM
- pH Factor .....6.8 - 7.3

Water which does not meet these standards should be treated with the installation of Middleby's Water Treatment System. Call 919-762-1000 if you have questions concerning your water meeting these parameters.

\*Failure or malfunction of this appliance due to poor water quality is not covered under warranty.

As continued product improvement is a policy of Crown, specifications are subject to change without notice.

# INTRODUCTION

## DESCRIPTION

The model EPX-3 steamer comes equipped with a standard 9.0 kW heating block that can be reduced to 6 kW on single phase supplies. Model EPX-5 steamer comes equipped with a standard 15.0 kW heating block that can be reduced to 10 kW on single phase supplies.

Your new steamer has been designed and manufactured to meet the toughest industry standards. The best possible workmanship and materials along with laboratory tests have been utilized in its design.

Proper installation, care and maintenance will give you years of reliable, trouble free operation.

The EPX-3 and EPX-5 are electric fired pressureless steam cookers. The cooking compartments are equipped with a three-piece door with inner gasket plate isolated from the exterior surface. Door latch operates by slam action for positive sealing of the door. Operating controls are displayed on a front-mounted panel and include indicator lights for ready and cooking modes, a timer to set cook times and an illuminated rocker mode selection switch for TIMED COOKING, OFF and CONSTANT STEAM.

## BASIC FUNCTIONING

The cooker is ready for operation when the READY light comes on.

At the end of the set interval, timer contacts switch to shut off the cooking operation and sounds a signal buzzer and will maintain a safe food holding temperature at or above 150F. The buzzer is silenced by returning the timer dial to the OFF position. The READY light will be illuminated.

# INSTALLATION INSTRUCTIONS

## UNPACKING

### IMMEDIATELY INSPECT FOR SHIPPING DAMAGE

Immediately after unpacking the steamer, check for possible shipping damage. If the steamer is found to be damaged after unpacking, save the packaging materials and contact the carrier within 15 days of delivery. File a claim regardless of extent of damage.

We cannot assume responsibility for damage or loss incurred in transit.

Prior to installation, verify that the electrical service agrees with the specifications on the machine data plate which is located on the left side panel.

## LOCATION

Allow space for vent and electrical connection. Minimum clearances for proper air circulation is 2" on the sides and 6" on the back. Allow adequate access for servicing.

## LEVELLING

Using a spirit level, adjust the feet to level the unit, front to back and side to side. The unit must be level for proper operation. Warranty will be void for improper installation.

## ELECTRICAL CONNECTIONS

### **WARNING**

The unit must be electrically grounded and comply with local codes, or in the absence of local codes with the national electrical code ANSI/NFPA to latest edition. Canadian installation must comply with CSA Standard (C22.2 No. 109-M1981 General Requirements Canadian Electrical Code, Part II 109-M1981) for commercial cooking appliances.

### **WARNING**

Disconnect electrical power supply and place a tag at the disconnect switch to indicate that you are working on circuit.

Use copper wire suitable for at least 200E Fahrenheit (90° Celsius). The steamer must be grounded. The wiring diagram is located on the right side panel as you face the unit.

Make electrical connection through the 1-1/8" (29 mm) diameter hole provided using 3/4" (19 mm) trade size conduit. Refer to the wiring diagram located inside the right side panel. Use 90°C minimum insulated wire.

## PLUMBING CONNECTIONS

No plumbing connections are required as steamer is filled manually.

## DRAIN CONNECTIONS

No drain connection is required.

## WATER CONDITION

For best results Crown recommends that the water supply meet the following specification:

Hardness: ..... Less than 2 grains or 35 ppm.

Total Dissolved Solids (TDS): ..... Less than 60 ppm.

PH Factor: ..... 7.0 to 7.5

This degree of hardness can easily be obtained with the use of a properly maintained water softener.

## VENT HOOD

Some local codes may require the steamer to be located under an exhaust hood. It is recommended that this steamer be located under an exhaust hood to remove excess steam during cooking operations.

Information on the construction and installation of ventilating hood may be obtained from the standard for "Vapor Removal for Cooking Equipment", NFPA No. 96 (Latest Edition).

### **WARNING**

For an appliance equipped with casters, the installation shall be made with an adequate flexible electrical conduit; adequate means must be provided to limit the movement of the appliance without depending on or transmitting stress to the electrical conduit; the location where restraining means may be attached is to the rear of the stand, below power supply connection.

# TESTING PROCEDURES

 **WARNING**

The steamer and its parts are hot. Use care when operating, cleaning or servicing the steamer. The cooking compartment contains live steam and hot water. Stay clear while opening the door.

Once the steamer is installed, thoroughly test the steamer before operation.

1. Check that door opens and closes for proper operation.
2. Inspect the door gasket to ensure there is no damage.
3. Check without water in the steamer and with "CONTINUOUS" cooking mode selected, that the "LOW WATER" indicator and alarm comes on within 10 minutes of a cold start.
4. Open compartment door and pour in water up to the "Water Level" mark located at back of compartment.
5. Select TIMED COOKING mode with the power switch and set the timer to the OFF position.
6. Close door and wait approximately 10 minutes for the READY indicator to illuminate which will indicate the unit is up to proper operating temperature.
7. Open the door to verify the cavity has reached cooking temperature. Water in the bottom of the cooking cavity should be between 200 to 210°F.
8. Set the timer to 5 minutes and close the door to initiate the cooking cycle. The COOKING indicator should illuminate. Allow the timed cooking cycle to complete, verifying that the end of cycle buzzer sounds and the COOKING indicator is out. The 'READY' light will illuminate.

## BEFORE FIRST USE

Clean the protective oils from all surfaces of the steamer. Use a non-corrosive, grease dissolving commercial cleaner, following manufacturer's directions. Rinse thoroughly and wipe dry with a soft clean cloth.

 **WARNING**

The steamer and its parts are hot. Use care when operating, cleaning or servicing the steamer. The cooking compartment contains live steam and hot water. Stay clear while opening the door.

# OPERATION

## CONTROLS

1. **Door Handle**  
Move handle up to open door to cooking cavity.
2. **Ready Pilot Light**  
When lit, indicates the steamer cavity is above 150°F (65°C) and is ready for the cooking cycle.
3. **Cooking Pilot Light**  
When lit, indicates that a cooking cycle is in progress.
4. **Timer Dial**  
Set the cooking time (0 to 60 minutes) - steam cooking will begin after the door is closed. The cooking cycle will be interrupted if the door is opened during the cooking cycle; resume cooking by closing the door. Holding temperature in the cavity will keep cooked foods warm after cooking cycle, at or above 150°F (65°C).
5. **Main Power Switch**  
**TIMED COOKING** - The steamer will begin heating to the pre-set temperature for standby. Red light will illuminate on the main power switch. Cooking cycle is determined by timer dial.  
**OFF** - The steamer is powered off.  
**CONTINUOUS STEAM** - Steamer will heat to enter into a continuous cooking cycle. Both indicator lights will remain off during continuous steam cooking cycles.
6. **Add Water Pilot Light**  
Illuminates to indicate a low water condition or that the temperature of the heater element is above normal. A buzzer will also sound an audible alarm.
7. **Drain Handle**  
Use to drain the steamer at end of day.

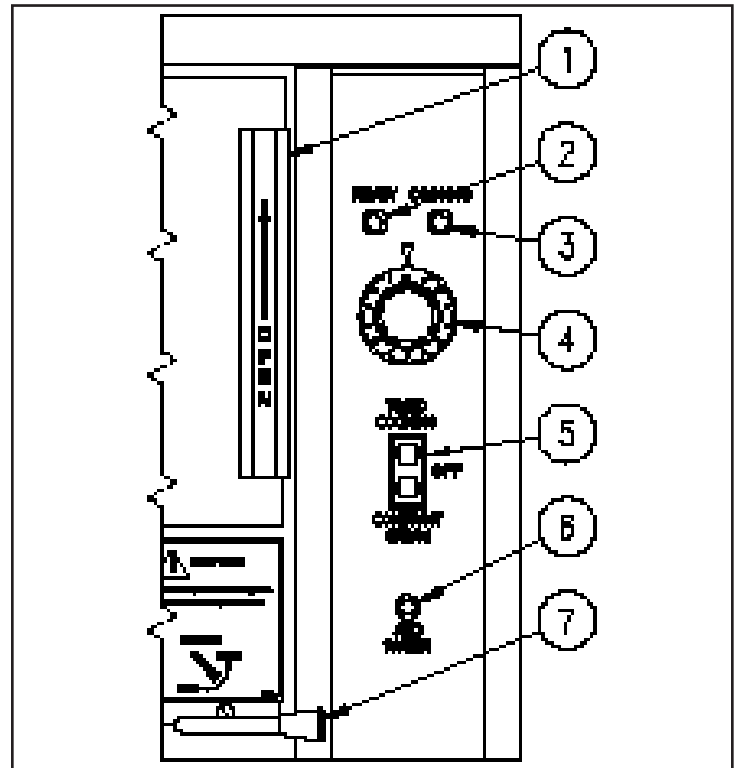

## COOKING

### CAUTION

Live steam and accumulated hot water in the compartment may be released when the door is opened.

1. Close drain valve.
2. Remove the deflector plate to expose the bottom of the cavity.
3. Pour water through the door up to the "WATER LEVEL" mark on the back wall of the cavity and then replace the deflector plate.
4. Close the door, select "TIMED COOKING" mode with the power switch and set the timer to one minute position. The unit will be ready for operation in approximately ten minutes when the "READY" indicator lamp is illuminated and the buzzer sounds.
5. Turn the timer to "OFF" position to silence the buzzer, slide pans of food into cooking compartment pan supports and close cooking compartment door.
6. Select "CONSTANT STEAM" or "TIMED COOKING" mode.
7. In "CONSTANT STEAM" mode the unit will begin the cooking cycle and continue indefinitely until user intervention or unit runs out of water. There are no indicator lights illuminated in this mode.
8. In "TIMED COOKING" mode the unit will run through the cooking cycle determined by number of minutes selected with the timer. The end of the cooking cycle is indicated by the buzzer and the illuminated "READY" lamp. The unit will hold the cooked foods in a warm state and will maintain the cooking cavity at or above 150°F (65°C) with the timer set to the "OFF" position.
9. The cooking cycle may be interrupted at any time by opening the compartment door. To resume operation, close the door.
10. Open door slightly at first letting most of the steam out of the compartment and then fully open the door.
11. Unload by sliding pans of food from pan supports.
12. Close the door to ensure the unit is ready for the next cook cycle.

## SHUTDOWN

### CAUTION

When the unit is not in use, leave the cooking compartment doors ajar to prolong the life of the door gasket.

1. Drain the steamer after each day's use.
2. Set the power switch to "OFF".

### CAUTION

Drain water is very hot and can cause severe personal injury.

3. Drain the steamer into a suitable receptacle capable of holding 3 gallons of boiling water.
4. Thoroughly clean the unit.

# CLEANING

 **WARNING**

Disconnect the power supply to the appliance before cleaning or servicing.

 **WARNING**

Never use chlorine or bleach solution for cleaning door gasket.

Never use steel wool or other metallic pads to clean the steamer.

Weekly, or more often if necessary, clean the exterior with damp cloth and polish with soft dry cloth.

Use a non-abrasive cleaner to remove discolourations.

After each period of daily operation (more frequently as required to maintain cleanliness), the cooker should be thoroughly cleaned by completing the following steps:

1. Perform SHUTDOWN procedure.
2. Remove the deflector plate and pan supports by lifting up and off mounting studs and wash with a mild detergent.
3. When the unit has cooled, use hot soapy water to clean the interior of the steamer and thoroughly rinse and dry all surfaces with a clean dry cloth.
4. Inspect the drain opening to assure there are no obstructions.
5. Replace the pan supports and deflector in compartment and leave door ajar.

 **WARNING**

When this appliance is installed with casters and is connected to the supply service with flexible electrical conduit, a restraint to prevent damage to the electrical conduit should have been installed. If disconnection of the restraint is necessary, reconnect this restraint after the appliance has been returned to its originally installed position.

# COOKING GUIDELINES

1. Frozen vegetables should always be cooked in perforated 12" x 20" x 2-1/2" (1/1 65 mm) pans, 7-1/2 lbs. (3.4 kg) maximum per pan.
2. Frozen entrees should be underlined with a perforated pan for best results. If they are defrosted first, the heating time will be decreased.
3. Fresh foods may also be cooked in this unit. Vegetables and other foods where the stock is not to be retained should be cooked in perforated 12" x 20" x 2-1/2" (1/1 65 mm) pans for the most nutritious results.
4. Total cooking time will vary depending on the load, even though the timer setting is the same.
5. All foods, except cakes and pastry, can be cooked in a steam cooking unit.
6. Steam cooked meals have greater nutritional value since they retain most of their vitamins and minerals.
7. Because foods are cooked faster by the higher temperatures of steam cooking, they can be prepared closer to serving time, insuring maximum freshness.
8. Steam cooked foods have a higher percent yield more portions per dollar spent.
9. Food may be served from the same pan in which it is steam cooked, thus reducing food breakage since there is no extra handling or transferring of food from cooking pans to serving pans. It also reduces pot washing tasks.
10. Some important advantages of steam cooking are labour saving, reduced operating costs, space saving, and the lifting of heavy stock pots is eliminated.
11. Rice and pasta products, if thoroughly wet at the start of the cooking process, are very easily prepared.
12. Food such as potatoes, poultry, seafood, and some meats may be blanched in the steam cooker, thus reducing the total cooking time and grease absorption.
13. The steam cooker will loosen foods burned on pans making washing easier.
14. Solid pans are recommended when liquid is to be retained and perforated pans when the liquid is not to be retained.
15. Eggs may be cooked out of the shell if they are to be chopped which eliminates peeling after steaming.
16. The steam cooker can be opened during the cooking period to add or remove items.

## STEAM COOKING

Your steamer efficiently cooks vegetables or other foods for immediate serving. Steam cooking should be carefully time controlled. Keep hot food holding time to a minimum to produce the most appetizing results. Prepare small batches, cook only enough to start serving, then cook additional amounts to meet demand. Separate frozen foods into smaller pieces to allow more efficient cooking.

Use a pan cover for pre-cooked frozen dishes that cannot be cooked in the covered containers in which they are packed if they require more than 15 minutes of cooking time. When cover is used, approximately one-third additional cooking time is necessary.

Cooking time for frozen foods depends on amount of defrosting required. If time permits, allow frozen foods to partially thaw overnight in a refrigerator. This will reduce their cooking time.

## PREPARATION

Prepare vegetables, fruits, meats, seafood and poultry normally by cleaning, separating, cutting, removing stems, etc. Cook root vegetables in a perforated pan unless juices are being saved. Liquids can be collected in a solid 12" x 20" pan placed under a perforated pan. Perforated pans are used for frankfurters, wieners and similar items when juices do not need to be preserved. Solid pans are good for cooking puddings, rice and hot breakfast cereals. Vegetables and fruits are cooked in solid pans in their own juices. Meats and poultry are cooked in solid pans to preserve their own juices or to retain broth. Canned foods can be heated in their opened cans (cans placed in 12" x 20" solid pans) or the contents may be poured into solid pans.

The steamer compartment is designed to accept combinations of the pan of 12" x 20" (either solid or perforated) as shown on the following table.

DEPTH OF PAN	NUMBER OF PANS	
	EPXN-3	EPXN-5
1"	6	10
2 1/2"	3	5
4"	2	3
6"	1	2

# PREVENTIVE MAINTENANCE

A good preventive maintenance program begins with the daily cleaning procedure. Additional preventive maintenance operations are presented in this section. In establishments that employ full-time maintenance personnel, the tasks described can be assigned to them. For other installations, tasks requiring mechanical or electrical experience should be performed by an authorized service agency.

The following paragraphs are set for minimum preventive maintenance procedures that must be completed periodically to assure continued trouble-free operation of the cooker.

## CAUTION

Under no circumstances should hardware (or parts) be replaced with a different length, size, or type other than as specified in the parts list. The hardware used in the cooker has been selected or designed specifically for its application, and the use of other hardware may damage the equipment and will void any warranty.

## WARNING

Disconnect the power supply to the appliance before cleaning or servicing.

## CAUTION

The steamer and its parts are hot. Use care when operating, cleaning or servicing the steamer. The cooking compartment contains live steam. Stay clear when opening door.

## CLEANING

At the end of each day, or between cooking cycles if necessary:

## CAUTION

Do not use cleaning agents that are corrosive.

## NOTICE

Contact the factory, the factory representative or a local service company to perform maintenance and repairs should the appliance malfunction. Refer to warranty terms.

Weekly, or more often if necessary:

1. Clean exterior with a damp cloth and polish with a soft dry cloth.
2. Use a non-abrasive cleaner to remove discolourations.

It is **NOT RECOMMENDED** to use cleaning agents that are corrosive.

Use of cleaning agents that contain chloride, acids or salts which are corrosive may cause pitting and corrosion when used over a period of time; this will reduce the life of the appliance.

Should pitting or corrosion occur, this is not covered by warranty.

Follow the recommended cleaning instructions. Use a mild detergent, warm water and rinse thoroughly.

## WARNING

NEVER SPRAY WATER INTO ELECTRIC CONTROLS OR LOUVRES.

## REMOVAL OF SCALE DEPOSITS

 **WARNING**

Disconnect the power supply to the appliance before cleaning or servicing.

It is recommended that your steamer be descaled once a week.

Your steamer comes with a sixteen weeks supply of Middleby QuickClean Scale Control product (16 oz. container). QuickClean is a safe and efficient way to maintain a scale-free environment for your steamer. Weekly descaling will enhance the life of your steamer. Scale build up can damage your steamer and expose you to costly repairs. Failure or malfunction of this appliance due to scale build up is not covered under warranty. Read and follow instructions on the QuickClean bottle.

To order QuickClean or if you have questions about this product call 480-591-4073.

## DESCALING PROCEDURE

 **WARNING**

Read and follow instructions on the QuickClean bottle. Use plastic or rubber gloves to avoid skin contact. If QuickClean comes in contact with skin, rinse with clean water.

1. Set power switch to "OFF".
2. Remove diffuser plate and pan support racks.
3. Fill the cavity with water up to the "WATER LEVEL" line.
4. Spread one scoop of QuickClean (1 oz) evenly to the water.
5. Allow 8 to 16 hours to clean.
6. Drain, rinse and wipe the bottom of the cavity.

# TROUBLESHOOTING

## GENERAL

PROBLEM	PROBABLE CAUSE	REMEDY
1. COOKING INDICATOR LIGHT FAILS TO LIGHT WITH TIMER SET.	a. Main power circuit breaker tripped.	Locate external circuit breaker for incoming power and place in ON position.
	b. Door interlock switch contacts not closed.	Shut cooker door to close switch contacts. Check alignment of door with switch.
	c. Door interlock switch faulty.	Replace switch.
	d. Indicator light burned out.	Replace light.
	e. Faulty timer contacts.	Replace timer.
	f. Faulty wiring.	Inspect condition of wire and tightness of all connections. Correct as needed.
	g. Fuse blown.	Replace with same rated fuse.
2. STEAM FAILS TO GENERATE WITH COOKING INDICATOR LIGHT ON.	a. Faulty wiring.	Inspect condition of wire and tightness of all connections. Correct as needed.
3. STEAMS CONTINUOUSLY WITHOUT THE COOKING OR READY LIGHT ON .	a. Faulty thermostatic switch.	Replace thermostat.
	b. Power switch - continuous steam setting is selected.	This is normal operation when "continuous steam" is selected.
4. TIMER DIAL NOT TURNING.	a. Faulty timer motor.	Replace timer.
	b. Faulty wiring.	Inspect condition of wire and tightness of all connections. Correct as needed.
5. BUZZER FAILS TO SOUND AT END OF TIMER SETTING.	a. Timer contacts faulty.	Replace timer.
	b. Buzzer faulty.	Replace buzzer.
	c. Faulty wiring.	Inspect condition of wire and tightness of all connections. Correct as needed.

### WARNING

Use care while working with control panel. Terminals carry 240 Volts.

## COMPONENT TESTING

### 60-MINUTE TIMER

#### Timer Contacts

Defective timer contacts will result in failure of cooker compartment to operate. When this occurs, remove the side panel and proceed as follows:

1. Turn off power to the cooker at external circuit breaker.
2. Disconnect all three wires from timer terminals.
3. Connect an ohmmeter between terminals 1 and 3.
4. Rotate timer dial beyond the "0 - Minute" point (any setting) to obtain a reading of zero ohms on the ohmmeter. If zero ohm reading cannot be obtained, timer contacts are defective and the timer must be replaced.
5. Move ohmmeter leads to terminals 1 and 4.
6. Rotate timer dial to "0 - Minute" position. (An audible click indicates correct position). If zero ohm reading cannot be obtained, the timer is defective and must be replaced.
7. Remove ohmmeter and replace all three leads on timer terminals.

## Timer Motor

A defective timer motor will cause continuous operation in the TIME mode, with the timer dial failing to return to the “0 - Minute” position.

To confirm timer motor condition, proceed as follows:

1. Carefully check motor wire leads and tighten loose connections.
2. Turn on power to the steamer.
3. Set timer dial (any setting beyond “0 - Minute”). If operation is correct, the motor will turn the dial toward “0 - Minute”. If the motor fails to operate, it is defective and the entire timer must be replaced.
4. Shut off power to the cooker.

## Door Interlock Switch

Malfunction of the cooker door interlock switch prevents timer indicator lights from turning on and steam generator from operating when the timer dial is set. If steam does not enter the compartment and the cooking indicator light fails to turn on with the door latch securely engaged, the fault may be in the door interlock switch. Proceed as follows:

1. Turn off power to the cooker.
2. Disconnect wires to the door switch terminals.
3. Connect an ohmmeter between the terminals of the switch. The switch is marked “C” for common, “NC” for normally closed and “NO” for normally open.
4. Actuate the switch by closing the cooking compartment door. If a zero reading cannot be obtained between the C and NO terminals, the switch is defective and must be replaced.
5. Remove the ohmmeter and replace the leads on switch terminals.

## Indicator Lights

If the cooker compartment functions correctly, with the single exception that the indicator light fails to light during operation, the fault is a defective indicator light. A “burned out” or defective light is verified by using an AC voltmeter at the leads, with input power on the selector switch in the correct position for that timer, the timer set, and the door latches closed. If 240 volts is present, the fault is in the indicator light and requires replacement. If 240 volts is not present, the fault is in the wiring or control components (selector switch, timer or door switch).

## Buzzer

If the buzzer does not sound at the termination of the operator-selected timer setting (timer dial returned to “0 - Minute” position), the fault may be a defective buzzer. Buzzer operation is verified using an AC voltmeter at buzzer coil connections with input power on and selector switch and coinciding timer dial set at the “0 - Minute” position. If voltage is 240 volts, the fault is in the buzzer, which must be replaced. If 240 volts is not present, the fault is in the wiring or control components (timer or selector switch).

## Wiring

### **WARNING**

Disconnect the power supply to the appliance before cleaning or servicing.

Using an ohmmeter, wiring continuity between the connections shown on the wiring diagram is readily verified. This is best done in stages, removing only those wires required for each continuity check. As each lead is replaced, it should be checked for evidence of corrosion, and cleaned if necessary. All leads must be tightly attached so as to provide a good electrical connection.

## Door Gasket

Check gasket for cuts and replace if necessary.

## Door Gasket Replacement

The cooking compartment door gaskets are made of a silicone-type rubber material that is very durable but subject to wear during normal operation. Should the gasket leak replace it.

1. Open the cooking compartment door.
2. Remove the six or eight screws from the gasket plate in the door panel assembly.
3. Remove the gasket plate and the door gasket from door panel.
4. Install the new door gasket to the door panel. Replace the gasket plate and six or eight screws.
5. Gasket replacement is now complete.

Door may be difficult to close until gasket has compressed to conform to opening. Leaving door closed overnight will compress gasket.

## Exterior Panel Removal

### **WARNING**

To prevent hazard in servicing the cooker, be certain that the electrical disconnect circuit breaker for the steamer is OFF before removing side panels.

Access to all internal plumbing and electrical assemblies is from the right side. The right-side panel is removed by removing the bottom screws from panel.

## STAINLESS STEEL

To remove normal dirt, grease or product residue from stainless steel, use ordinary soap and water (with or without detergent) applied with a sponge or cloth. Dry thoroughly with a clean cloth. Never use vinegar or any corrosive cleaner.

To remove grease and food splatters or condensed vapours that have baked on the equipment, apply cleanser to a damp cloth or sponge and rub cleanser on the metal in the direction of the polishing lines on the metal. Rubbing cleanser as gently as possible in the direction of the polished lines will not mar the finish of the stainless steel. **NEVER RUB WITH A CIRCULAR MOTION.**

Soil and burnt deposits which do not respond to the above procedure can usually be removed by rubbing the surface with SCOTCH-BRITE scouring pads or STAINLESS scouring pads. **DO NOT USE ORDINARY STEEL WOOL** as any particles left on the surface will rust and further spoil the appearance of the finish. **NEVER USE A WIRE BRUSH, STEEL SCOURING PADS (EXCEPT STAINLESS), SCRAPER, FILE OR OTHER STEEL TOOLS.** Surfaces which are marred collect dirt more rapidly and become more difficult to clean. Marring also increases the possibility of corrosive attack. Refinishing may then be required.

## TO REMOVE HEAT TINT

Darkened areas sometimes appear on the stainless steel surface where the area has been subjected to excessive heat. These darkened areas are caused by thickening of the protective surface of the stainless steel and are not harmful. Heat tint can normally be removed by the foregoing, but tint which does not respond to this procedure calls for a vigorous scouring in the direction of the polish lines using SCOTCH-BRITE scouring pads or a STAINLESS scouring pad in combination with a powdered cleanser. Heat tint action may be lessened by not applying or by reducing heat to equipment during slack periods.

NOTES



## NOTES

# EPX-3 & EPX-5

## Electric Counter Pan Steamers



A product with the Crown name incorporates the best in durability and low maintenance. We all recognize, however, that replacement parts and occasional professional service may be necessary to extend the useful life of this appliance. When service is needed, contact a Crown Authorized Service Agency, or your dealer. To avoid confusion, always refer to the model number, serial number, and type of your appliance.



### CROWN FOOD SERVICE EQUIPMENT

 **MIDDLEBY** A Middleby Company

70 Oakdale Road, Downsview (Toronto) Ontario, Canada, M3N 1V9  
Telephone: 919-762-1000      [www.crownsteamgroup.com](http://www.crownsteamgroup.com)